

JETSTREAM TOOLING™ MDT

ADDITIONS METRIC AND INCH VERSIONS

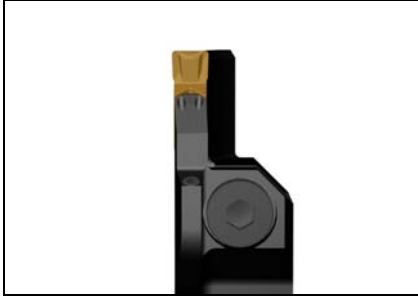

Toolholders for inserts LCGN, LCMF and LCMR



• Inserts, please see MN2009 Turning pages 323-329, 333-334

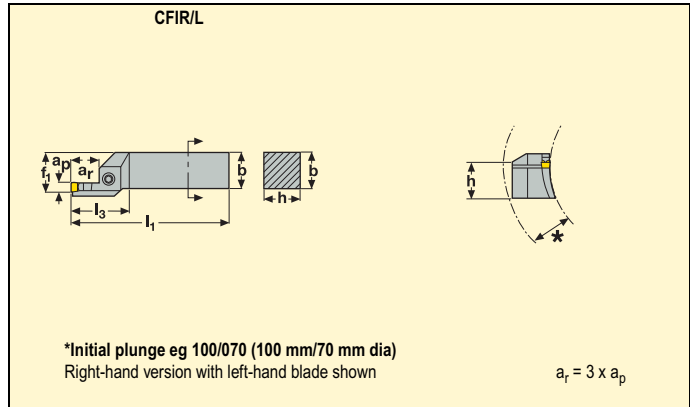

| Application | Initial plunge** | Part No. | Dimensions in mm | | | | | | KG | Seat size | Insert | | |
|-------------|------------------|----------|------------------|--------------------|----------------|----------------|----------------|----------------|----|-----------|--------|---|------------|
| | | | h | b | l ₁ | f ₁ | l ₃ | a _r | | | | | |
| | 03 | 100/070 | CFIR | 2525M03R100070-JET | 25 | 25 | 150 | 26,5 | 33 | 9 | 0,7 | 3 | LC..1603.. |
| | | 130/090 | | 2525M03R130090-JET | 25 | 25 | 150 | 26,5 | 33 | 9 | 0,7 | 3 | LC..1603.. |
| | | 170/110 | | 2525M03R170110-JET | 25 | 25 | 150 | 26,5 | 33 | 9 | 0,7 | 3 | LC..1603.. |
| | | 100/070 | CFIL | 2525M03L100070-JET | 25 | 25 | 150 | 26,5 | 33 | 9 | 0,7 | 3 | LC..1603.. |
| | | 130/090 | | 2525M03L130090-JET | 25 | 25 | 150 | 26,5 | 33 | 9 | 0,7 | 3 | LC..1603.. |
| | | 170/110 | | 2525M03L170110-JET | 25 | 25 | 150 | 26,5 | 33 | 9 | 0,7 | 3 | LC..1603.. |
| | 04 | 100/070 | CFIR | 2525M04R100070-JET | 25 | 25 | 150 | 26,5 | 36 | 12 | 0,7 | 4 | LC..1604.. |
| | | 130/090 | | 2525M04R130090-JET | 25 | 25 | 150 | 26,5 | 36 | 12 | 0,7 | 4 | LC..1604.. |
| | | 170/110 | | 2525M04R170110-JET | 25 | 25 | 150 | 26,5 | 36 | 12 | 0,7 | 4 | LC..1604.. |
| | | 230/140 | | 2525M04R230140-JET | 25 | 25 | 150 | 26,5 | 36 | 12 | 0,7 | 4 | LC..1604.. |
| | | 100/070 | CFIL | 2525M04L100070-JET | 25 | 25 | 150 | 26,5 | 36 | 12 | 0,7 | 4 | LC..1604.. |
| | | 130/090 | | 2525M04L130090-JET | 25 | 25 | 150 | 26,5 | 36 | 12 | 0,7 | 4 | LC..1604.. |
| | | 170/110 | | 2525M04L170110-JET | 25 | 25 | 150 | 26,5 | 36 | 12 | 0,7 | 4 | LC..1604.. |
| | | 230/140 | | 2525M04L230140-JET | 25 | 25 | 150 | 26,5 | 36 | 12 | 0,7 | 4 | LC..1604.. |
| | | | | | | | | | | | | | |
| | | | | | | | | | | | | | |
| | | | | | | | | | | | | | |
| | | | | | | | | | | | | | |
| | | | | | | | | | | | | | |

**Initial plunge relates to face groove diameter

Spare Parts, Parts included in delivery

| Toolholder/ Insert dimension | Clamp screw/ Key | Torque value Nm |
|------------------------------------|------------------|-----------------|
| ..03.. | TCEI0513 | 4 SMS795 |
| ..04.. | TCEI0613 | 5 SMS795 |
| | | |
| | | |
| | | |
| | | |
| | | |

Please check availability in current price and stock-list

Toolholders for inserts LCGN, LCMF and LCMR



• Inserts, please see MN2009 Turning pages 323-329, 333-334

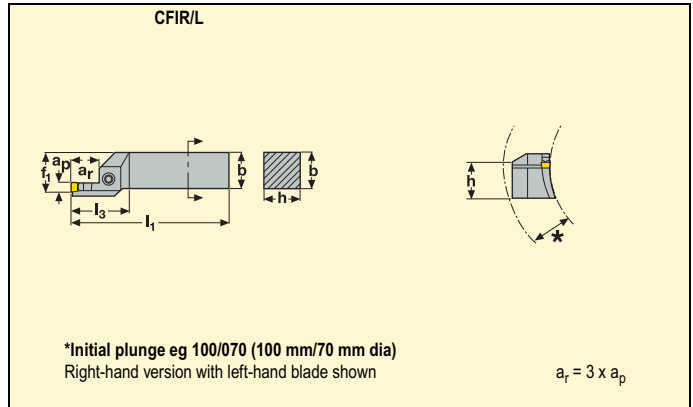

| Application | Initial plunge** | Part No. | Dimensions in mm | | | | | | KG | Seat size | Insert | | |
|-------------|------------------|----------|--------------------|--------------------|----------------|----------------|----------------|----------------|----|-----------|--------|------------|------------|
| | | | h | b | l ₁ | f ₁ | l ₃ | a _r | | | | | |
| | 05 | 100/070 | CFIR | 2525M05R100070-JET | 25 | 25 | 150 | 26,5 | 40 | 15 | 0,7 | 5 | LC..1605.. |
| | | 130/090 | | 2525M05R130090-JET | 25 | 25 | 150 | 26,5 | 40 | 15 | 0,7 | 5 | LC..1605.. |
| | | 170/110 | | 2525M05R170110-JET | 25 | 25 | 150 | 26,5 | 40 | 15 | 0,7 | 5 | LC..1605.. |
| | | 230/140 | | 2525M05R230140-JET | 25 | 25 | 150 | 26,5 | 40 | 15 | 0,7 | 5 | LC..1605.. |
| | | 100/070 | CFIL | 2525M05L100070-JET | 25 | 25 | 150 | 26,5 | 40 | 15 | 0,7 | 5 | LC..1605.. |
| | | 130/090 | | 2525M05L130090-JET | 25 | 25 | 150 | 26,5 | 40 | 15 | 0,7 | 5 | LC..1605.. |
| | 170/110 | | 2525M05L170110-JET | 25 | 25 | 150 | 26,5 | 40 | 15 | 0,7 | 5 | LC..1605.. | |
| | 230/140 | | 2525M05L230140-JET | 25 | 25 | 150 | 26,5 | 40 | 15 | 0,7 | 5 | LC..1605.. | |
| | 06 | 100/070 | CFIR | 2525M06R100070-JET | 25 | 25 | 150 | 26,5 | 46 | 18 | 0,7 | 6 | LC..1606.. |
| | | 130/190 | | 2525M06R130090-JET | 25 | 25 | 150 | 26,5 | 46 | 18 | 0,7 | 6 | LC..1606.. |
| | | 170/110 | | 2525M06R170110-JET | 25 | 25 | 150 | 26,5 | 46 | 18 | 0,7 | 6 | LC..1606.. |
| | | 230/140 | | 2525M06R230140-JET | 25 | 25 | 150 | 26,5 | 46 | 18 | 0,7 | 6 | LC..1606.. |
| | | 100/070 | CFIL | 2525M06L100070-JET | 25 | 25 | 150 | 26,5 | 46 | 18 | 0,7 | 6 | LC..1606.. |
| | | 130/190 | | 2525M06L130090-JET | 25 | 25 | 150 | 26,5 | 46 | 18 | 0,7 | 6 | LC..1606.. |
| 170/110 | | | 2525M06L170110-JET | 25 | 25 | 150 | 26,5 | 46 | 18 | 0,7 | 6 | LC..1606.. | |
| 230/140 | | | 2525M06L230140-JET | 25 | 25 | 150 | 26,5 | 46 | 18 | 0,7 | 6 | LC..1606.. | |

**Initial plunge relates to face groove diameter

Spare Parts, Parts included in delivery

| Toolholder/ Insert dimension | Clamp screw/ Key | Torque value Nm |
|------------------------------------|------------------|-----------------|
| ..05.. | TCEI0613 | 5 SMS795 |
| ..06.. | TCEI0815 | 6 SMS795 |
| | | |
| | | |
| | | |
| | | |
| | | |

Please check availability in current price and stock-list

Toolholders for inserts LCGN, LCMF and LCMR

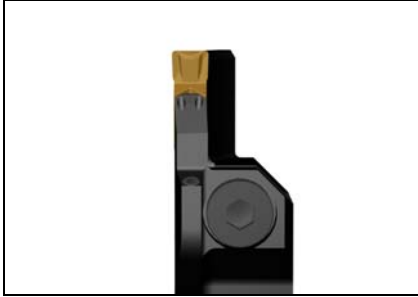

• Inserts, please see MN2008 Turning, Inch pages 358-359, 361

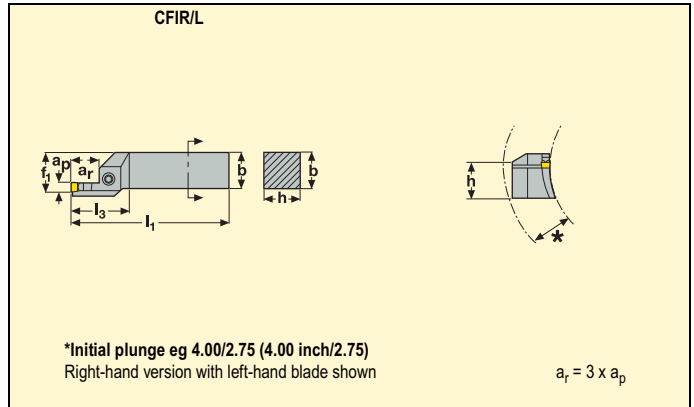

| Application | a_p | Initial plunge** | Part No. | Dimensions in inch | | | | | | | lbs | Seat size | |
|-------------|-------|------------------|-----------------------------|--------------------|------|-------|-------|-------|-------|-----|-----|------------|--|
| | | | | h | b | l_1 | f_1 | l_3 | a_r | | | | |
| | .03 | 4.00/2.75 | CFIR 100 03D-R4.00 2.75-JET | 1.00 | 1.00 | 6 | 1.04 | 33 | .355 | 1.5 | 3 | LC..1603.. | |
| | | 5.00/3.50 | 100 03D-R5.00 3.50-JET | 1.00 | 1.00 | 6 | 1.04 | 33 | .355 | 1.5 | 3 | LC..1603.. | |
| | | 6.70/4.30 | 100 03D-R6.70 4.30-JET | 1.00 | 1.00 | 6 | 1.04 | 33 | .355 | 1.5 | 3 | LC..1603.. | |
| | | 4.00/2.75 | CFIL 100 03D-L4.00 2.75-JET | 1.00 | 1.00 | 6 | 1.04 | 33 | .355 | 1.5 | 3 | LC..1603.. | |
| | | 5.00/3.50 | 100 03D-L5.00 3.50-JET | 1.00 | 1.00 | 6 | 1.04 | 33 | .355 | 1.5 | 3 | LC..1603.. | |
| | | 6.70/4.30 | 100 03D-L6.70 4.30-JET | 1.00 | 1.00 | 6 | 1.04 | 33 | .355 | 1.5 | 3 | LC..1603.. | |
| | .04 | 4.00/2.75 | CFIR 100 04D-R4.00 2.75-JET | 1.00 | 1.00 | 6 | 1.04 | 36 | .473 | 1.5 | 4 | LC..1604.. | |
| | | 5.00/3.50 | 100 04D-R5.00 3.50-JET | 1.00 | 1.00 | 6 | 1.04 | 36 | .473 | 1.5 | 4 | LC..1604.. | |
| | | 6.70/4.30 | 100 04D-R6.70 4.30-JET | 1.00 | 1.00 | 6 | 1.04 | 36 | .473 | 1.5 | 4 | LC..1604.. | |
| | | 9.00/5.50 | 100 04D-R9.00 5.50-JET | 1.00 | 1.00 | 6 | 1.04 | 36 | .473 | 1.5 | 4 | LC..1604.. | |
| | | 4.00/2.75 | CFIL 100 04D-L4.00 2.75-JET | 1.00 | 1.00 | 6 | 1.04 | 36 | .473 | 1.5 | 4 | LC..1604.. | |
| | | 5.00/3.50 | 100 04D-L5.00 3.50-JET | 1.00 | 1.00 | 6 | 1.04 | 36 | .473 | 1.5 | 4 | LC..1604.. | |
| | | 6.70/4.30 | 100 04D-L6.70 4.30-JET | 1.00 | 1.00 | 6 | 1.04 | 36 | .473 | 1.5 | 4 | LC..1604.. | |
| | | 9.00/5.50 | 100 04D-L9.00 5.50-JET | 1.00 | 1.00 | 6 | 1.04 | 36 | .473 | 1.5 | 4 | LC..1604.. | |
| | | | | | | | | | | | | | |
| | | | | | | | | | | | | | |
| | | | | | | | | | | | | | |
| | | | | | | | | | | | | | |
| | | | | | | | | | | | | | |

**Initial plunge relates to face groove diameter

Spare Parts, Parts included in delivery

| Toolholder/ Insert dimension | Clamp screw/ Key | |
|------------------------------------|------------------|----------|
| | | |
| ..03 | TCEI0513 | 4 SMS795 |
| ..04 | TCEI0613 | 5 SMS795 |
| | | |
| | | |
| | | |
| | | |

Please check availability in current price and stock-list

Toolholders for inserts LCGN, LCMF and LCMR

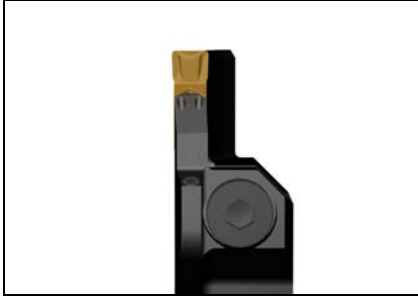

- Inserts, please see MN2008 Turning, Inch pages 358-359, 361

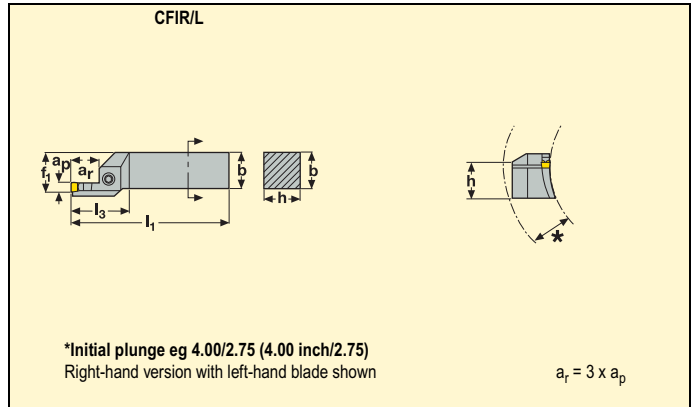

| Application | a_p | Initial plunge** | Part No. | Dimensions in inch | | | | | | | Seat size | |
|-------------|-------|------------------|-----------------------------|--------------------|------|-------|-------|-------|-------|-----|-----------|------------|
| | | | | h | b | l_1 | f_1 | l_3 | a_r | | | |
| | 05 | 4.00/2.75 | CFIR 100 05D-R4.00 2.75-JET | 1.00 | 1.00 | 6 | 1.04 | 40 | .591 | 1.5 | 5 | LC..1605.. |
| | | 5.00/3.50 | 100 05D-R5.00 3.50-JET | 1.00 | 1.00 | 6 | 1.04 | 40 | .591 | 1.5 | 5 | LC..1605.. |
| | | 6.70/4.30 | 100 05D-R6.70 4.30-JET | 1.00 | 1.00 | 6 | 1.04 | 40 | .591 | 1.5 | 5 | LC..1605.. |
| | | 9.00/5.50 | 100 05D-R9.00 5.50-JET | 1.00 | 1.00 | 6 | 1.04 | 40 | .591 | 1.5 | 5 | LC..1605.. |
| | | 4.00/2.75 | CFIL 100 05D-L4.00 2.75-JET | 1.00 | 1.00 | 6 | 1.04 | 40 | .591 | 1.5 | 5 | LC..1605.. |
| | | 5.00/3.50 | 100 05D-L5.00 3.50-JET | 1.00 | 1.00 | 6 | 1.04 | 40 | .591 | 1.5 | 5 | LC..1605.. |
| | | 6.70/4.30 | 100 05D-L6.70 4.30-JET | 1.00 | 1.00 | 6 | 1.04 | 40 | .591 | 1.5 | 5 | LC..1605.. |
| | | 9.00/5.50 | 100 05D-L9.00 5.50-JET | 1.00 | 1.00 | 6 | 1.04 | 40 | .591 | 1.5 | 5 | LC..1605.. |
| | 06 | 4.00/2.75 | CFIR 100 06D-R4.00 2.75-JET | 1.00 | 1.00 | 6 | 1.04 | 46 | .709 | 1.5 | 6 | LC..1606.. |
| | | 5.00/3.50 | 100 06D-R5.00 3.50-JET | 1.00 | 1.00 | 6 | 1.04 | 46 | .709 | 1.5 | 6 | LC..1606.. |
| | | 6.70/4.30 | 100 06D-R6.70 4.30-JET | 1.00 | 1.00 | 6 | 1.04 | 46 | .709 | 1.5 | 6 | LC..1606.. |
| | | 9.00/5.50 | 100 06D-R9.00 5.50-JET | 1.00 | 1.00 | 6 | 1.04 | 46 | .709 | 1.5 | 6 | LC..1606.. |
| | | 4.00/2.75 | CFIL 100 06D-L4.00 2.75-JET | 1.00 | 1.00 | 6 | 1.04 | 46 | .709 | 1.5 | 6 | LC..1606.. |
| | | 5.00/3.50 | 100 06D-L5.00 3.50-JET | 1.00 | 1.00 | 6 | 1.04 | 46 | .709 | 1.5 | 6 | LC..1606.. |
| | | | | | | | | | | | | |
| | | | | | | | | | | | | |
| | | | | | | | | | | | | |
| | | | | | | | | | | | | |
| | | | | | | | | | | | | |

**Initial plunge relates to face groove diameter

Spare Parts, Parts included in delivery

| Toolholder/ Insert dimension | Clamp screw/ Key | |
|------------------------------------|------------------|----------|
| | | |
| ..05 | TCEI0613 | 5 SMS795 |
| ..06 | TCEI0815 | 6 SMS795 |
| | | |
| | | |
| | | |
| | | |

Please check availability in current price and stock-list

Toolholders for inserts LCGN, LCMF and LCMR

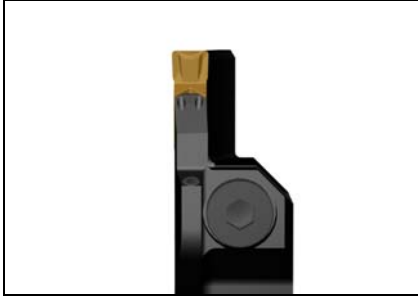

• Inserts, please see MN2008 Turning, Inch pages 358-359, 361

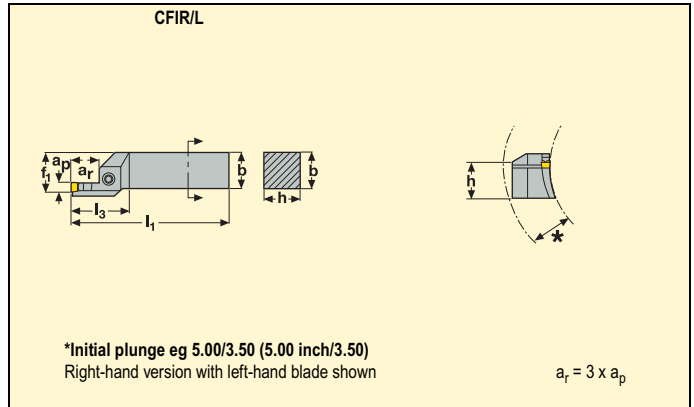

| Application | a_p a_r | Initial plunge** | Part No. | Dimensions in inch | | | | | | | Seat size | | |
|-------------|-------------|------------------|-----------------------------|--------------------|------|-------|-------|-------|-------|-----|-----------|------------|--|
| | | | | h | b | l_1 | f_1 | l_3 | a_r | | | | |
| | 08 | 5.00/3.50 | CFIR 125 08E-R5.00 3.50-JET | 1.25 | 1.25 | 7 | 1.31 | 56 | .946 | 2.6 | 8 | LC..3008.. | |
| | | 6.70/4.30 | 125 08E-R6.70 4.30-JET | 1.25 | 1.25 | 7 | 1.31 | 56 | .946 | 2.6 | 8 | LC..3008.. | |
| | | 9.00/5.50 | 125 08E-R9.00 5.50-JET | 1.25 | 1.25 | 7 | 1.31 | 56 | .946 | 2.6 | 8 | LC..3008.. | |
| | | 19.70/8.00 | 125 08E-R19.7 8.00-JET | 1.25 | 1.25 | 7 | 1.31 | 56 | .946 | 2.6 | 8 | LC..3008.. | |
| | | 5.00/3.50 | CFIL 125 08E-L5.00 3.50-JET | 1.25 | 1.25 | 7 | 1.31 | 56 | .946 | 2.6 | 8 | LC..3008.. | |
| | | 6.70/4.30 | 125 08E-L6.70 4.30-JET | 1.25 | 1.25 | 7 | 1.31 | 56 | .946 | 2.6 | 8 | LC..3008.. | |
| | | 9.00/5.50 | 125 08E-L9.00 5.50-JET | 1.25 | 1.25 | 7 | 1.31 | 56 | .946 | 2.6 | 8 | LC..3008.. | |
| | | 19.70/8.00 | 125 08E-L19.7 8.00-JET | 1.25 | 1.25 | 7 | 1.31 | 56 | .946 | 2.6 | 8 | LC..3008.. | |
| | | | | | | | | | | | | | |
| | | | | | | | | | | | | | |

**Initial plunge relates to face groove diameter

Spare Parts, Parts included in delivery

| Toolholder/ Insert dimension | Clamp screw/ Key | |
|------------------------------------|------------------|----------|
| | | |
| ..08 | TCEI1020 | 6 SMS795 |
| | | |
| | | |
| | | |
| | | |

Please check availability in current price and stock-list