

Square shoulder and slot milling cutters

Square 6™ - 217.96-04

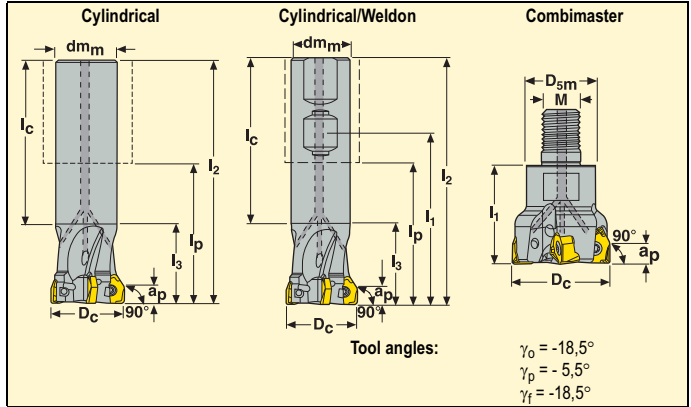

- For insert selection and cutting data recommendations, see pages 169-170
- For complete insert programme, see page 552 .
- For plunging, see page 597



Part No.	Dimension in mm											Type of mounting	
	D _c	D _{sm} dm _m	l ₁	M l ₂	l _p	l ₃	l _c	a _p					
R217.96 -2020.0-04-2A	20	20	–	150	100	29	121	4	2	0,7	29400	Cylindrical	XNEX04
-2020.0-04-3A	20	20	–	150	100	29	121	4	3	0,7	29400	Cylindrical	XNEX04
-2525.0-04-4A	25	25	–	170	114	29	141	4	4	0,6	26300	Cylindrical	XNEX04
-2525.0-04-5A	25	25	–	170	114	29	141	4	5	0,6	26300	Cylindrical	XNEX04
-3232.0-04-5A	32	32	–	195	135	31	164	4	5	1,2	23200	Cylindrical	XNEX04
-3232.0-04-6A	32	32	–	195	135	31	164	4	6	1,2	23200	Cylindrical	XNEX04
R217.96 -2020.3-04-2A	20	20	65	90	40	29	61	4	2	0,2	29400	Cyl/Weldon	XNEX04
-2020.3-04-3A	20	20	65	90	40	29	61	4	3	0,2	29400	Cyl/Weldon	XNEX04
-2525.3-04-4A	25	25	69	101	45	34	67	4	4	0,3	26300	Cyl/Weldon	XNEX04
-2525.3-04-5A	25	25	69	101	45	34	67	4	5	0,3	26300	Cyl/Weldon	XNEX04
-3232.3-04-5A	32	32	69	105	45	37	68	4	5	0,6	23200	Cyl/Weldon	XNEX04
-3232.3-04-6A	32	32	69	105	45	37	68	4	6	0,6	23200	Cyl/Weldon	XNEX04
R217.96 -1020.RE-04-2A	20	18,3	28	M10	–	–	–	4	2	0,1	29400	Combimaster*	XNEX04
-1020.RE-04-3A	20	18,3	28	M10	–	–	–	4	3	0,1	29400	Combimaster*	XNEX04
-1225.RE-04-4A	25	23	30	M12	–	–	–	4	4	0,2	26300	Combimaster*	XNEX04
-1225.RE-04-5A	25	23	30	M12	–	–	–	4	5	0,2	26300	Combimaster*	XNEX04
-1632.RE-04-5A	32	30	40	M16	–	–	–	4	5	0,3	23200	Combimaster*	XNEX04
-1632.RE-04-6A	32	30	40	M16	–	–	–	4	6	0,3	23200	Combimaster*	XNEX04

For shanks and dimensions, see pages 498 - 510.

Spare parts

For cutter	Locking screw	Key *
R217.96..	C02506-T08P	T08P-3

* Torque value 1,2 Nm. Dynamometric keys, see page 590.

Please check availability in current price and stock-list.

Square 6™ – 220.96-04



- For insert selection and cutting data recommendations, see pages 169-170
- For complete insert programme, see page 552.
- For plunging, see page 596.

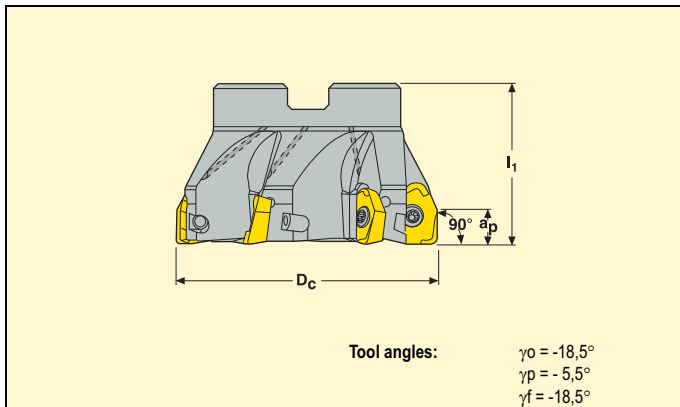

Pitch	Part No.	Dimensions in mm						
		D _c	l ₁	a _p				
Normal	R220.96 -0040-04-6A	40	40	4	6	0,2	20700	XNEX04
	-0050-04-8A	50	40	4	8	0,4	18600	XNEX04
	-0063-04-9A	63	40	4	9	0,7	16500	XNEX04
Close	R220.96 -0040-04-7A	40	40	4	7	0,2	20700	XNEX04
	-0050-04-9A	50	40	4	9	0,4	18600	XNEX04
	-0063-04-10A	63	40	4	10	0,7	16500	XNEX04

Spare parts

	Locking screw	Key *	Arbor screw
For cutter			
R220.96-0040	C02506-T08P	T08P-3	TCEI0825
R220.96-0050	C02506-T08P	T08P-3	220.17-692
R220.96-0063	C02506-T08P	T08P-3	-

* Torque value 1,2 Nm. Dynamometric keys, see page 590.

Dimensions of mounting

	Dimensions in mm				For arbor	
	For cutter	dm _m	D _{sm}	B _{kw}		c
R220.96-0040..		16	35	8,4	5,6	16
R220.96-0050..		22	47	10,4	6,3	22
R220.96-0063..		27	52	12,4	7	27

Please check availability in current price and stock-list.

Square shoulder and slot milling cutters

Square 6™ – 220.96-08



- For insert selection and cutting data recommendations, see pages 171 - 172.
- For complete insert programme, see page 552.
- For plunging, see page 596.

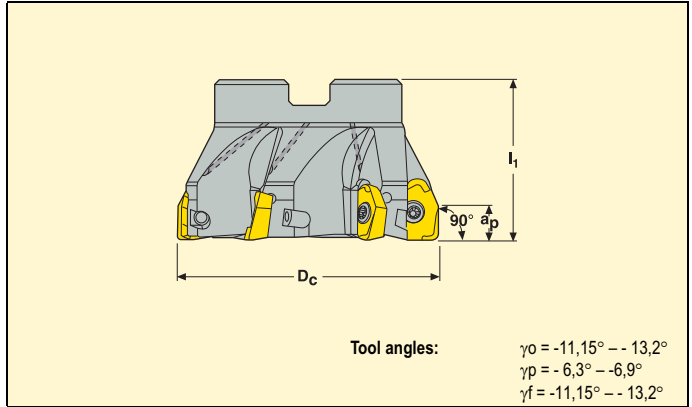

Pitch	Part No.	Dimensions in mm						
		D _c	l ₁	a _p				
Normal	R220.96 -0050-08-4A	50	40	7,5	4	0,3	10600	XNEX0806
	-0063-08-6A	63	40	7,5	6	0,4	9400	XNEX0806
	-0063-08-6A-27	63	40	7,5	6	0,4	9400	XNEX0806
	-0080-08-7A	80	50	7,5	7	1,0	8400	XNEX0806
	-0100-08-8A	100	50	7,5	8	1,5	7500	XNEX0806
	-0125-08-11A	125	63	7,5	11	2,8	6700	XNEX0806
	-8160-08-12	160	63	7,5	12	4,8	5900	XNEX0806

Spare parts

	Locking screw	Key *	Arbor screw
For cutter			
R220.96-0050	C04011-T15P	T15P-4	220.17-696
R220.96-0063	C04011-T15P	T15P-4	220.17-692
R220.96-0080-8160	C04011-T15P	T15P-4	–

* Torque value 3,5 Nm. Dynamometric keys, see page 590.

Dimensions of mounting

	Dimensions in mm					For arbor	
	For cutter	dm _m	D _{5m}	B _{kw}	c		d _{hc1}
	R220.96-0050-0063	22	47	10,4	6,3	–	22
	R220.96-0063-08-6A-27	27	62	12,4	7	–	27
	R220.96-0080	27	62	12,4	7	–	27
	R220.96-0100	32	77	14,4	8	–	32
	R220.96-0125	40	90	16,4	9	–	40
	R220.96-8160	40	90	16,4	9	66,7	40

Please check availability in current price and stock-list.

Square shoulder and slot milling cutters

Square 6™ – 220.96-08



- For insert selection and cutting data recommendations, see pages 171 - 172.
- For complete insert programme, see page 552.
- For plunging, see page 596.

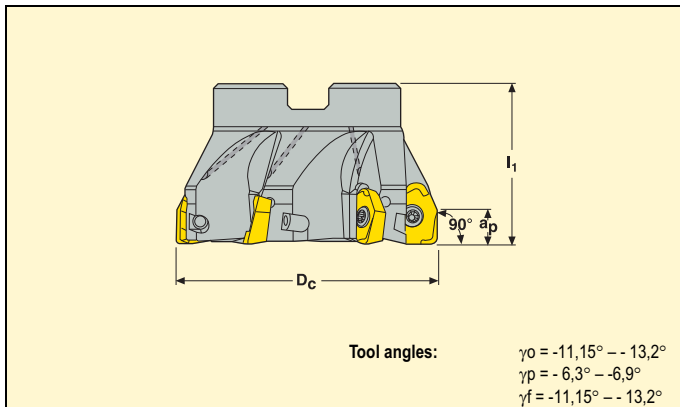

Pitch	Part No.	Dimensions in mm						
		D _c	l ₁	a _p				
Close	R220.96 -0050-08-5A	50	40	7,5	5	0,3	10600	XNEX0806
	-0063-08-7A	63	40	7,5	7	0,4	9400	XNEX0806
	-0063-08-7A-27	63	40	7,5	7	0,4	9400	XNEX0806
	-0080-08-9A	80	50	7,5	9	1,0	8400	XNEX0806
	-0100-08-11A	100	50	7,5	11	1,5	7500	XNEX0806
	-0125-08-14A	125	63	7,5	14	2,8	6700	XNEX0806
	-8160-08-16	160	63	7,5	16	4,8	5900	XNEX0806

Spare parts

	Locking screw	Key *	Arbor screw
For cutter			
R220.96-0050	C04011-T15P	T15P-4	220.17-696
R220.96-0063	C04011-T15P	T15P-4	220.17-692
R220.96-0080-8160	C04011-T15P	T15P-4	-

* Torque value 3,5 Nm. Dynamometric keys, see page 590.

Dimensions of mounting

	Dimensions in mm					For arbor	
	For cutter	d _m	D _{5m}	B _{kw}	c		d _{hc1}
	R220.96-0050-0063	22	47	10,4	6,3	-	22
	R220.96-0063-08-7A-27	27	47	10,4	6,3	-	27
	R220.96-0080	27	62	12,4	7	-	27
	R220.96-0100	32	77	14,4	8	-	32
	R220.96-0125	40	90	16,4	9	-	40
	R220.96-8160	40	90	16,4	9	66,7	40

Please check availability in current price and stock-list.

Square shoulder and slot milling cutters

Square 6™ – 220.96-08



- For insert selection and cutting data recommendations, see pages 171 - 172.
- For complete insert programme, see page 552 .
- For plunging, see page 596.

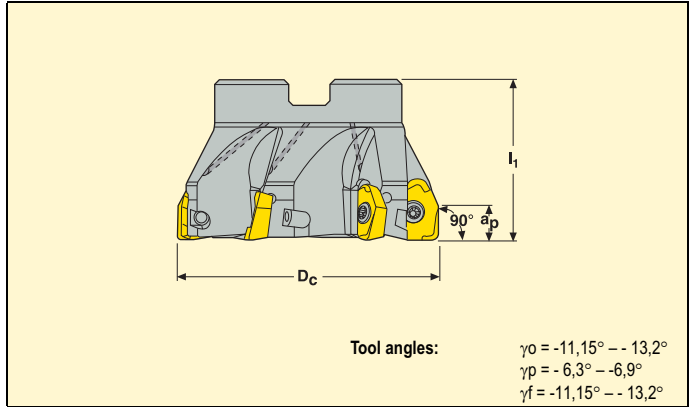

Pitch	Part No.	Dimensions in mm						
		D_c	l_1	a_p				
Coarse	R220.96 -0063-08-4A	63	40	7,5	4	0,4	9400	XNEX0806
	-0080-08-5A	80	50	7,5	5	1	8400	XNEX0806
	-0100-08-6A	100	50	7,5	6	1,5	7500	XNEX0806
	-0125-08-7A	125	63	7,5	7	2,8	6700	XNEX0806

Spare parts

	Locking screw	Key *	Arbor screw
For cutter			
R220.96-0063	C04011-T15P	T15P-4	220.17-692
R220.96-0080-0125	C04011-T15P	T15P-4	-

* Torque value 3,5 Nm. Dynamometric keys, see page 590.

Dimensions of mounting

	Dimensions in mm				For arbor	
	For cutter	dm_m	D_{sm}	B_{kw}		c
	R220.96-0063	22	47	10,4	6,3	22
	R220.96-0080	27	62	12,4	7	27
	R220.96-0100	32	77	14,4	8	32
	R220.96-0125	40	90	16,4	9	40

Please check availability in current price and stock-list.