



SECOMAX CBN060K
A NEW GENERATION OF PCBN CUTTING TOOLS

SECO 



CBN060K

PARTNERS IN CASE HARDENED STEEL MACHINING SOLUTIONS

Case hardened steel is a unique material coupling a hard and wear resistant outer skin with a tough impact resistant core. The result is a material with desirable properties for harsh environments such as automotive gearboxes and drive train components.

The nature and use of components produced in case hardened steel demand high and repeatable machined tolerances, surface finishes and surface integrity. To meet these demands PCBN cutting tools have evolved to offer a cost effective and reliable machining solution for case hardened steel components.

Seco has been very active in the machining of case hardened steel for many years, offering class leading grades such as CBN050C and CBN160C. We are continuing to demonstrate that through grade and format innovation we are able to meet your ever increasing demands.



DEVELOPMENT THROUGH INNOVATION

As well as offering class leading grades, Seco prides itself on its innovation, being the first and only company to offer solid PCBN for case hardened steel machining as well as offering unique high performance products such as the helix and crossbill wiper inserts.

With the launch of CBN060K, Seco will combine many new technologies and unique concepts to offer you a whole new level of product performance.

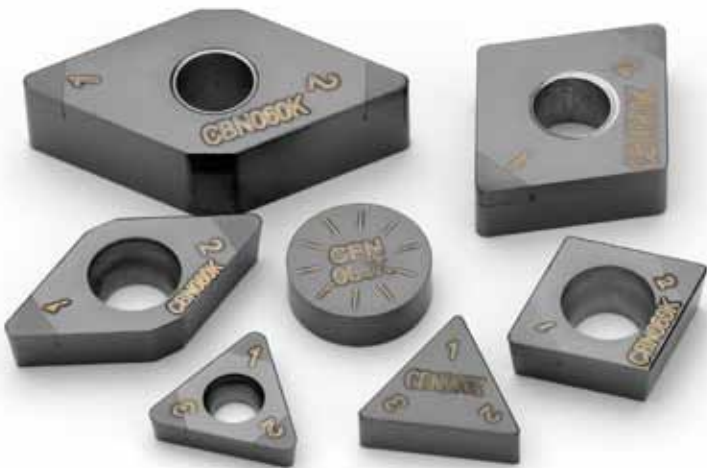

THE SIX FEATURES OF CBN060K THAT WILL IMPROVE YOUR PRODUCTIVITY

Secomax CBN060K has been designed specifically for turning case hardened steels within the application area of H10 – H20. The grade is the result of extensive development and relies on several entirely novel and patented technologies.

Let us show you the benefits of our advanced technologies and more importantly what they mean to you.

1

MULTI-LAYER K COATING (PATENT PENDING) – ENHANCING PERFORMANCE

The coating of PCBN cutting tools for case hardened steel machining is now an established performance enhancer. However, with the invention of our new multi-layer K coating (patent pending), Seco have now taken coating technology to new heights. The multi-layer coating invention coupled with optimisation of pre-treatments and PVD deposition techniques have resulted in a coating which enhances a product performance by levels not seen in the industry before.

COATING BENEFITS

- Improved wear resistance =
- Reduced crater wear development =
- Improved chip flow =
- Increased substrate compressive stresses =

BENEFITS IN MACHINING

- = Prolonged and consistent tool life
- = Higher cutting speed options
- = Better chip evacuation and tool life
- = Reduce edge chipping and flaking

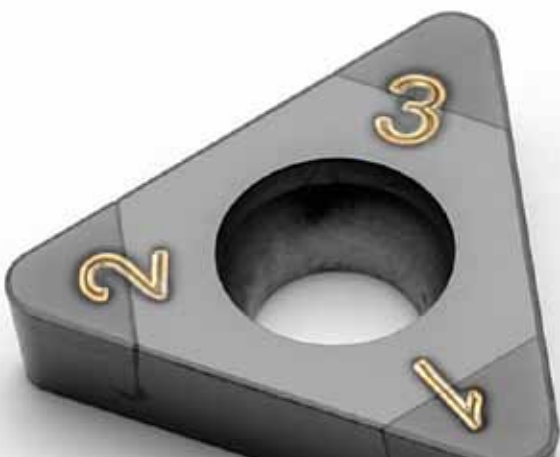



MICRON SIZED cBN PARTICLES - ENHANCING SURFACE FINISH

The core of any PCBN cutting tool is the cBN grit. The size distribution, make up and homogeneity all contribute to the product's ultimate performance. CBN060K incorporates a proprietary grade of micron sized cBN grain size and superior cBN particle distribution. The result is increased tool life and consistency coupled with a superb component surface finish.

2

MICRON SIZED cBN PARTICLE BENEFITS

Micron sized cBN particles = High quality surface finishes
Enhanced cBN particle distribution = Increased tool life & consistency

BENEFITS IN MACHINING



3

SUPERALLOY BINDER (PATENT PENDING) - A WORLD FIRST

CBN060K incorporates the world's first superalloy binder with a TiCN hard phase. This unique and special binder dramatically improves the material's mechanical properties without compromising on wear resistance. The enhanced product toughness offered by a superalloy binder gives you greater cutting edge reliability and tool life as well as the ability to machine at higher cutting speeds, thereby improving productivity.

SUPER ALLOY BINDER BENEFITS

Reduced chemical and attrition wear
Increased toughness
Enhanced cBN particle bonding

MACHINING BENEFITS

= Increases tool life and offers higher cutting speeds
= Improved chip resistance resulting in longer tool life
= Greater tool life

5

MULTIPLE PRODUCT FORMATS - OPTIMUM FORMAT FLEXIBILITY

Seco were the first and currently the only supplier to offer the same PCBN grade in a solid or brazed tip format with the launch of CBN050C. The success and flexibility offered by a multi-format grade is continued with CBN060K. The option of product formats give you the choice to run which ever format best suits your process without having the mix product grades and, therefore, process consistencies.

MULTIPLE FORMATS BENEFITS

The choice of solid or tipped inserts
Multi-tipped inserts
Solid PCBN format

MACHINING BENEFITS

= Product flexibility to meet all the machining requirements
= Common styles offering flexibility
= Economical multiple edges without braze joint

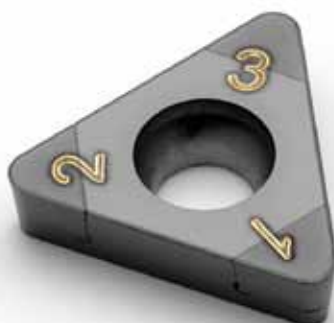

4

OPTIMISED CUTTING EDGE PROFILE FOR RELIABLE MACHINING

The accuracy and form of the cutting edge are key elements for long and predictable tool life. We have completed an exhaustive research and testing process to establish the optimum cutting edge, with the best possible chamfers and edge hone profiles. This will enable you to exploit the superb mechanical properties offered by CBN060K. These finely tuned cutting edge profiles offer you the best balance to give optimum and consistent tool life and maintain stable and consistent tolerances.

CUTTING EDGE PROFILE BENEFITS

Pure form edge hone radii
25 degree x 0.15mm chamfer

MACHINING BENEFITS

= Stable and consistent tool life and surface finish
= Optimum tool life and component tolerances



6

HELIX WIPER™ (PAT.) - A NEW TYPE OF WIPER TECHNOLOGY

Wiper technology is now an established method for decreasing cycle times and increasing productivity. However, the increased cutting forces associated with wiper inserts can sometimes create vibration and chatter. The Helix design of wiper is a clever system of changing the angle of the chamfer at different intersections of the wiper area and nose radii. Available in two versions the helix wiper can manipulate cutting forces and crater wear development. In unstable setups the positive Helix wiper (WZP) allows you to enjoy all the high feed rate benefits of wiper technology in setups which in the past would have resulted in chatter. Where wiper inserts are currently used, the negative Helix wiper (WZN) can significantly increase tool life by moving the crater wear away from the cutting edge.

HELIX WIPER™ BENEFITS

- Ability to run at high feed rates = Increased productivity
- Reduced contact time = Reduced tool wear and greater tool life
- Reduce cutting forces (WZP) = Option to use wipers in weak setups
- Increased tool life (WZN) = Less downtime, greater productivity

MACHINING BENEFITS

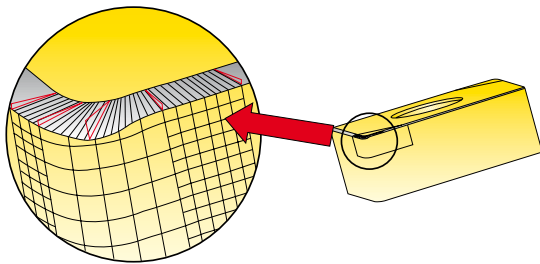

POSITIVE HELIX™ WZP

- Reduce vibrations in weak setups
- Lower radial cutting forces
- Suitable for unstable setups
- Can be used where standard wipers cause vibration

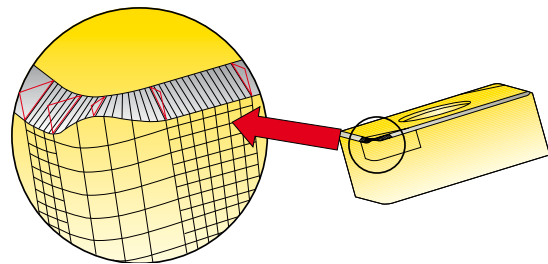

NEGATIVE HELIX™ WZN

- Stronger cutting edge
- Increased tool life
- Reduce vibrations in stable setups
- Increase compressive stresses

TEST RESULTS

GEAR WHEEL - CBN060K	
Component	Gear wheel
Operation	ID turning, continous cut
Material	DIN 16 MnCr 5, 60 HRC, Pre-machined
Insert	TNGX110308S-01525-WZ CBN060K
Cutting data	v_c 180 m/min
	f 0,38 mm/rev
	a_p 0,03 mm
Coolant	No
Result	CBN060K 1 200 parts/edge Competitor 1 000 parts/edge

Category	No. of parts / edge
Competitor	1000
CBN060K	1200

GEAR WHEEL - CBN060K	
Component	Timing gear
Operation	Od turning, continous cut
Material	Case hardened steel, 60 HRC, Pre-machined
Insert	CNGA120412S-01525-L1-B CBN060K
Cutting data	v_c 230 m/min
	f 0,12 mm/rev
	a_p 0,10 mm
Coolant	No
Result	CBN060K 240 parts/edge Competitor 175 parts/edge

Category	No. of parts / edge
Competitor	175
CBN060K	240

GEAR WHEEL - CBN060K	
Component	Gear wheel
Operation	ID turning, continous cut
Material	Case hardened steel, 58-62 HRC, Pre-machined
Insert	CNGA120412S-01525-L1-WZ-B CBN060K
Cutting data	v_c 160 m/min
	f 0,3 mm/rev
	a_p 0,15 mm
Coolant	No
Result	CBN060K 607 parts/edge Competitor 425 parts/edge

Category	No. of parts / edge
Competitor	425
CBN060K	607



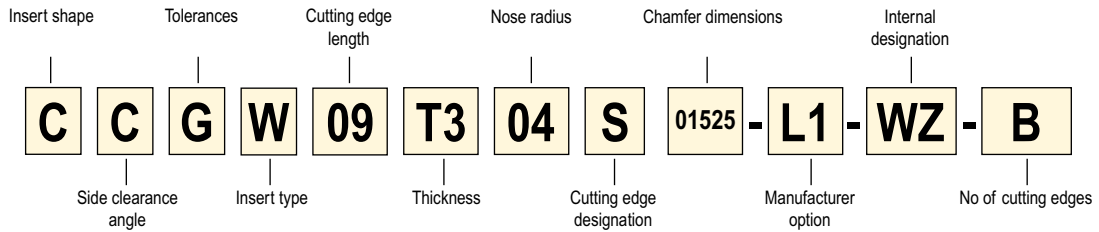

CODE KEY







INSERT PROGRAMME

INITIAL PROGRAMME

Inserts	Part No.	Grade
		CBN060K
	CNGA120408S-01525-L1-B	■
	CNGA120412S-01525-L1-B	■
	CNGA120408S-01525-L1-WZ-B	■
	TNGN110308S-01525	■
	TNGN110312S-01525	■
	TNGX110308S-01525-WZ	■

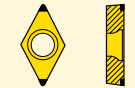
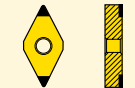
FOLLOW UP PROGRAMME (Q2 2010)

Inserts	Part No.	Grade
		CBN060K
	CCGW09T304S-01525-L1-B	■
	CNGA120408S-L1-WZN-B	■
	CNGA120408S-L1-WZP-B	■
	DCGW11T304S-01525-L1-B	■
	DCGW11T308S-01525-L1-B	■
	DNGA150408S-01525-L1-B	■
	DNGA150608S-01525-L1-B	■
	RNGN060300S-01525	■
	RNGN090300S-01525	■
	TCGW110204S-01525-L1-C	■
	TCGW110208S-01525-L1-C	■

Parameter guide - Recommended turning conditions Case hardened steel (55-62 HRC) - Turning

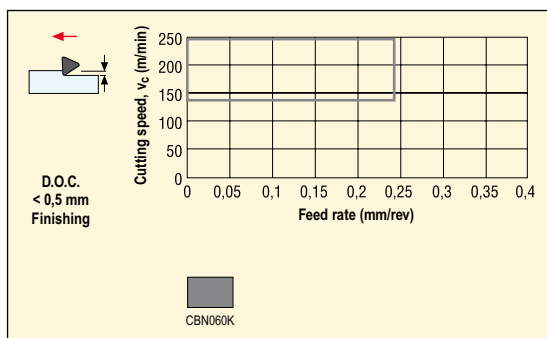

A close-up photograph of a grinding process. A dark, cylindrical grinding wheel is in contact with a metal workpiece. The wheel's surface is highly textured with fine abrasive grains. The workpiece is a dark metal block with a circular hole. The grinding wheel is positioned to grind the edge of the workpiece. The text "CBN060K" is visible on the side of the wheel.

CBN060K

ARGENTINA Seco Tools Argentina S.A. Tel: +54 11 48 92 00 60 Fax: +54 11 47 23 86 00.
AUSTRALIA Seco Tools Australia Pty. Ltd. Tel: +61 2 96 76 22 79 (local tel: 1300 55 7326) Fax: +61 2 96 76 61 58 (local fax: 1300 65 7326). **AUSTRIA** Seco Tools Ges.m.b.H Tel: +43 2253 210 40 Fax: +43 2253 210 4011. **BELGIUM** Seco Tools Benelux N.V./S.A. Tel: +32 2 389 09 60 Fax: +32 2 389 09 89. **BOSNIA** See Slovenia. **BRAZIL** Seco Tools Ind. e Com. Ltda. Tel: +55 15 2101 86 00 Fax: +55 15 2101 8606. **BULGARIA** See Sweden. **CANADA** Seco Tools Canada Inc. Tel: +1 905 693 1780 Fax: +1 905 693 1788. **CHINA** Seco Tools (Shanghai) Co., Ltd. Tel: +86 21 54 26 55 00 Fax: +86 21 64 85 56 85. **COLOMBIA** Rexco Tools Tel: +57 1 660 6030 Fax: +57 1 311 0026. **CROATIA** See Slovenia. **CZECH REPUBLIC** Seco Tools CZ s.r.o. Tel: +420 530 500 811 Fax: +420 530 500 810. **DENMARK** Seco Tools A/S Tel: +45 43 44 7600 Fax: +45 43 44 5030. **FINLAND** Seco Tools OY Tel: +358 09 2511 7200 Fax: +358 09 2511 7201. **FRANCE** Seco Tools France S.A. Tel: +33 2 48 67 27 27 Fax: +33 2 48 67 27 05, Seco EPB Tel: +33 3 88 71 38 89 Fax: +33 3 88 70 98 98, Seco Ets. Planche S.A. Tel: +33 4 74 83 26 54 Fax: +33 4 74 83 26 59. **GERMANY** Seco Tools GmbH Tel: +49 211 240 10 Fax: +49 211 240 12 75. **GREECE** Athens Mechanica Tel: +30 210 523 1284/5 Fax: +30 210 523 1286. **HUNGARY** Seco Tools KFT. Tel: +36 1 267 6720 Fax: +36 1 267 6721. **INDIA** Seco Tools India (P) Ltd. Tel: +91 21 3766 7300 Fax: +91 21 3766 7410. **INDONESIA** Seco Tools (SEA) Pte Ltd. Tel: +62 21 7918 6441/6442 Fax: +62 21 7918 6440. **ITALY** Seco Tools Italia S.p.A. Tel: +39 031 97 81 11 Fax: +39 031 97 85 91 (local fax: 840 000938). **JAPAN** Seco Tools Japan K.K. Tel: +81 3 37 33 81 11 Fax: +81 3 37 33 81 25. **MACEDONIA** See Slovenia. **MALAYSIA** Seco Tools Malaysia SDN. BHD Tel: +60 3 9059 1833 Fax: +60 3 9059 4833. **MEXICO** Seco Tools de Mexico Tel/Fax: +52 818 350 6311. **MONTENEGRO** See Slovenia. **NETHERLANDS** Seco Tools Benelux N.V. Tel: +31 183 63 66 00 Fax: +31 183 66 06 01, Seco Jabro Tools b.v. Tel: +31 77 463 24 44 Fax: +31 77 463 14 54. **NEW ZEALAND** Seco Tools New Zealand Ltd. Tel: +64 9 415 8441 Fax: +64 9 415 8442. **NORWAY** Seco Tools A/S Tel: +47 67 92 73 00 Fax: +47 67 92 73 02. **PHILIPPINES** See Singapore. **POLAND** Seco Tools (Poland) Sp. z.o.o. Tel: +48 22 637 5383 Fax: +48 22 637 5384. **PORTUGAL** Seco Tools Portugal, Lda. Tel: +351 256 371 650 Fax: +351 256 371 659. **ROMANIA** Seco Tools Romania S.R.L. Tel: +40 268 414 723 Fax: +40 268 476 772. **RUSSIA** Seco Tools Russia Tel: +7 495 680 1322 Fax: +7 495 680 6241. **SERBIA** Seco Tools SRB d.o.o Tel: +381 21 527 087 Fax: +381 21 527 093. **SINGAPORE** Seco Tools (SEA) Pte. Ltd. Tel: +65 68 41 28 02 Fax: +65 68 41 28 01. **SLOVAKIA** Seco Tools SK s.r.o. Tel: +421 33 551 3537 Fax: +421 33 551 3538. **SLOVENIA** Seco Tools SI d.o.o. Tel: +386 2 450 2340 Fax: +386 2 450 2341. **SOUTH AFRICA** Seco Tools South Africa (Pty.) Ltd. Tel: +27 11 362 2660 Fax: +27 11 362 1893. **SOUTH KOREA** Seco Tools Korea Ltd. Tel: +82 41 622 9785 Fax: +82 41 622 0985. **SPAIN** Seco Tools España S.A. Tel: +34 93 474 5533 Fax: +34 93 474 5550. **SWEDEN** Seco Tools AB Tel: +46 223 400 00 Fax: +46 223 718 60. **SWITZERLAND** Seco Tools AG Tel: +41 32 332 78 78 Fax: +41 32 332 78 79. **TAIWAN** Seco Tools (SEA) Taiwan Tel: +886 2 26 57 79 18 Fax: +886 2 26 57 94 61. **THAILAND** Seco Tools (Thailand) Co. Ltd. Tel: +66 2 74 67 801 Fax: +66 2 74 67 802. **TURKEY** Seco Tools A.S. Tel: +90 216 569 74 00 Fax: +90 216 575 73 83. **UKRAINE** Seco Tools Ukraine Tel: +38 056 790 05 44 Fax: +38 056 790 05 43. **UNITED KINGDOM** Seco Tools (U.K.) Ltd. Tel: +44 1789 76 43 41 Fax: +44 1789 76 11 70. **USA** Seco Tools Inc. Tel: +1 248 528 5200 Fax: +1 248 528 5250. **VIETNAM** Seco Tools (SEA) Pte. Ltd. Tel: +84 8 91 44 393/91 43 164 Fax: +84 8 91 43 164.



Seco Tools AB, 737 82 Fagersta, Sweden. Tel. +46 223 400 00.
www.secotools.com